



LUMINAIRE TESTING LABORATORY, INC.

SUSTAINING
MEMBER
of the
IESNA

905 Harrison Street · Allentown, PA 18103 · 610-770-1044 · Fax 610-770-8912 · www.LuminaireTesting.com

LTL NUMBER: 13190

DATE: 06-16-2008

PREPARED FOR: EB FLUORESCENT COMPANY, INC.

CATALOG NUMBER: G1X4 2/32 C

LUMINAIRE: FORMED WHITE ENAMEL STEEL HOUSING/REFLECTOR, CLEAR PRISMATIC PLASTIC LENS.

LAMPS: TWO 32 WATT T8 LINEAR FLUORESCENT LAMPS RATED AT 2850 LUMENS EACH.

LAMP CATALOG NUMBER: PHILIPS F32T8/TL841/ALTO

BALLAST: ONE UNIVERSAL LIGHTING TECHNOLOGIES B232IUNVHP-B

MOUNTING: RECESSED

TOTAL INPUT WATTS = 58.4 AT 120.0 VOLTS
THE 0 DEGREE PLANE IS PARALLEL WITH THE LAMPS.

#13190

CANDELA DISTRIBUTION

	0.0	22.5	45.0	67.5	90.0
0	826	826	826	826	826
5	822	823	823	824	824
15	793	794	795	799	799
25	729	731	735	739	740
35	630	631	629	632	631
45	483	473	470	454	450
55	311	300	285	260	255
65	163	149	130	133	129
75	83	81	71	83	88
85	33	31	28	37	34
90	0	0	0	0	0

FLUX

78
225
339
393
359
253
141
85
34

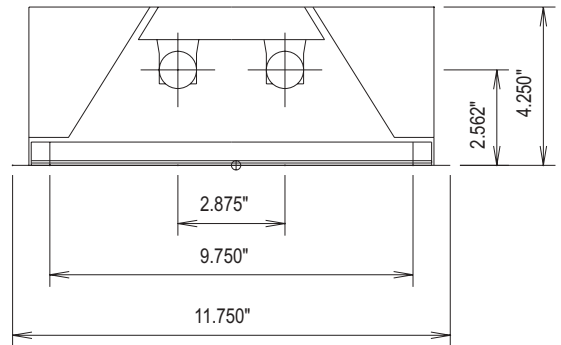

ZONAL LUMEN SUMMARY

ZONE	LUMENS	%LAMP	%FIXT
0- 30	642	22.5	33.7
0- 40	1035	36.3	54.3
0- 60	1648	57.8	86.4
0- 90	1907	66.9	100.0
90-180	0	0.0	0.0
0-180	1907	66.9	100.0

TOTAL LUMINAIRE EFFICIENCY: 66.9%
 TOTAL REFLECTANCE OF PAINT: 82.7%
 CIE TYPE: DIRECT
 PLANE: 0-DEG 90-DEG
 SPACING CRITERIA: 1.2 1.2

LUMINOUS LENGTH: 45.625 9.750

LUMINANCE IN CANDELA PER SQUARE METER

ANGLE IN DEG	AVERAGE 0-DEG	AVERAGE 45-DEG	AVERAGE 90-DEG
0	2878.	2878.	2878.
45	2380.	2316.	2217.
55	1889.	1731.	1549.
65	1344.	1072.	1063.
75	1117.	956.	1185.
85	1319.	1119.	1359.

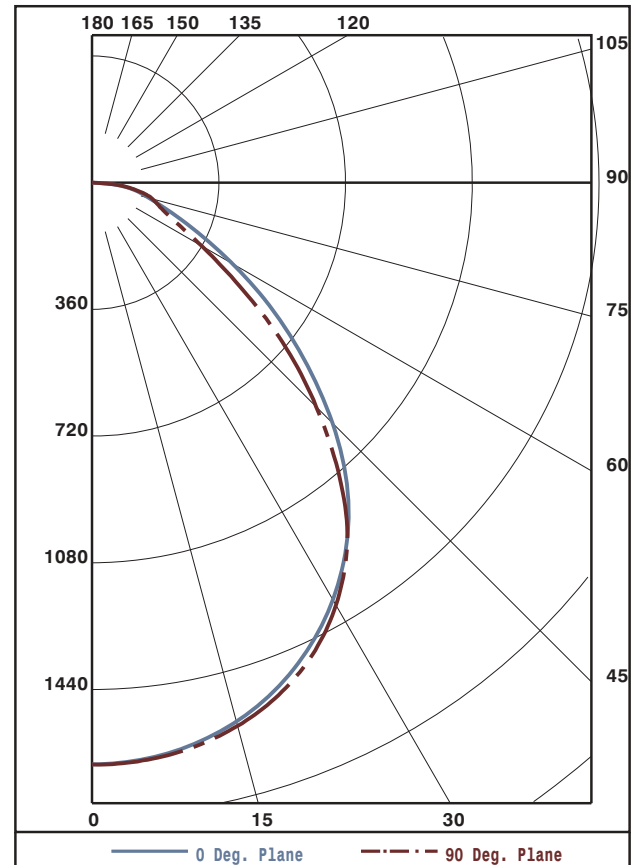

Approved By: MG

THIS REPORT BASED ON LM-41 AND OTHER PERTINENT IESNA PROCEDURES.



LUMINAIRE TESTING LABORATORY, INC.

SUSTAINING MEMBER of the IESNA

905 Harrison Street · Allentown, PA 18103 · 610-770-1044 · Fax 610-770-8912 · www.LuminaireTesting.com

LTL NUMBER: 13190

DATE: 06-16-2008

PREPARED FOR: EB FLUORESCENT COMPANY, INC.

COEFFICIENTS OF UTILIZATION - ZONAL CAVITY METHOD
EFFECTIVE FLOOR CAVITY REFLECTANCE 0.20

Table with 19 columns (RC, RW, 80, 70, 50, 30, 10, 0) and 11 rows of data.

CANDELA DISTRIBUTION

Table with 6 columns of candela values for various angles from 0 to 90 degrees.

ZONAL LUMEN SUMMARY

Table with 2 columns: Zonal Lumen range and Summary value.

THIS TEST WAS CONDUCTED USING RELATIVE PHOTOMETRY TECHNIQUES ACCORDING TO STANDARD IESNA PROCEDURES. THE USER MUST THEREFORE USE CAUTION IN THE FOLLOWING SITUATIONS: 1) THIS TEST WAS PERFORMED USING A SPECIFIC BALLAST/LAMP COMBINATION. EXTRAPOLATION OF THESE DATA FOR OTHER BALLAST/LAMP COMBINATIONS MAY PRODUCE ERRONEOUS RESULTS. 2) ACCORDING TO IESNA PROCEDURES, THE BALLAST(S) AND LAMP(S) ARE PRESUMED TO PRODUCE 100% OF RATED OUTPUT. AN APPROPRIATE BALLAST FACTOR MUST BE APPLIED TO THE LUMEN OUTPUT RATINGS AND LUMINOUS INTENSITY VALUES GIVEN. 3) THIS TEST WAS CONDUCTED IN A CONTROLLED LABORATORY ENVIRONMENT WHERE THE AMBIENT TEMPERATURE WAS HELD AT 25°C ±1°C. FIELD PERFORMANCE MAY DIFFER PARTICULARLY IN REGARDS TO CHANGE IN LUMINOUS OUTPUT AS A RESULT OF DIFFERENCE IN AMBIENT TEMPERATURE AND METHOD OF MOUNTING THE LUMINAIRE.